

---

ELIMINATE CORROSION AT PIPE SUPPORTS

**I-ROD<sup>®</sup>**

PRODUCT  
CATALOG



Universal Corrosion Coatings Pty Ltd



# I-ROD®

## ENDS CORROSION AT PIPE SUPPORTS

Corrosion at pipe supports is one of the leading causes of process piping failures, which can have potentially catastrophic results. All styles of pipe supports – including beam supports and pipe saddles – create crevices where water is trapped between the pipe and the support surface.

Corrosion can quickly undercut the paint film causing wall loss. If these conditions are not addressed, entire sections of pipe can fail and require replacement. Deepwater developed the I-Rod® pipe-support system to ensure longer, safer lives for pipes by eliminating the crevices between pipes and supports.



**Above**, the result of crevice corrosion on a pipe. Trapped moisture has caused substantial wall loss that could result in catastrophic failure.



**I-Rod®** eliminates the crevice by minimizing the contact area and allowing any moisture to evaporate. It's also much easier to inspect.

### WHAT CAUSES CREVICE CORROSION?

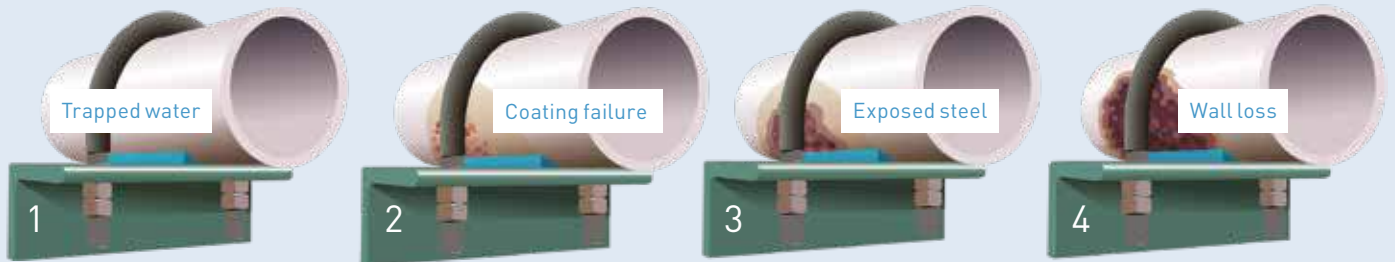

**1** Trapped water  
Water becomes trapped in the crevice between pipe and support.

**2** Coating failure  
Coatings are put in immersion service; they soften and fail.

**3** Exposed steel  
Bare steel is exposed to oxygenated water; corrosion begins.

**4** Wall loss  
Corrosion undercuts paint; localized wall loss on pipe begins.

### INDEX

- 3 How to order I-Rod®
- 4 Galvanized Nu-Bolts™
- 5 Nu-Bolts with high-temperature polyshrink
- 6 Cut and drilled I-Rod® without U-bolt
- 7 Stainless Steel and Sermagard™ Nu-Bolts™
- 8 Non-gripping I-Rod® with flats and Nu-Bolt™
- 9 Non-gripping I-Rod® with flats and Nu-Bolt™ XL
- 10 I-Rod® strips
- 11 U-bolts with polyshrink
- 12 U-bolts with high-temperature polyshrink
- 13 I-Rod® Clips for 360° clamps
- 14 I-Rod® Clips for 120° cradles
- 15 Nuts, washers, tape, adhesive
- 16 Nu-Bolt™ Torque Values
- 17 Temp. Recommendations for I-Rod® / Nu-Bolt™
- 18 I-Rod® installation tips
- 19 Make sure your I-Rod® is authentic
- 20 I-Rod® 28 year study

### HOW DOES I-ROD® PREVENT CREVICE CORROSION?

The pipe is supported by half-round shape, minimizing the contact area, ensuring water evaporates before damaging the paint.

The proprietary hydrophobic material has high compressive strength; it will not crack, creep, or cold-flow.

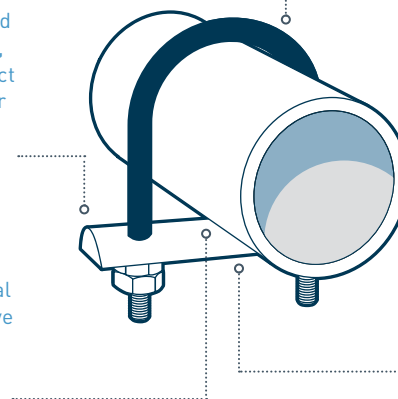

Nu-Bolts™ are covered with polyshrink to protect the paint on the pipe during installation.

I-Rod® electrically isolates the pipe from metal supports, preventing galvanic corrosion between dissimilar metals.

# HOW TO ORDER

## I-ROD®

### WHAT SIZE I-ROD IS REQUIRED?

Larger diameter I-Rod supports greater weights (i.e. 1" I-Rod can support up to 8,000 lb point load and 1 1/2" I-Rod can support 10,000 lb point load). Refer to the sizing chart below to ensure adequate support for your load requirements.



### WHAT'S THE OPERATING TEMPERATURE?

Determine your pipe's maximum operating temperature. Use standard I-Rod from -166°F (-110°C) up to 181°F (83°C); I-Rod HT up to 340°F (171°C) and PEEK for temperatures up to 480°F (249°C). The maximum operating temperature for polyshrink on Nu-Bolts is 230°F.



### WHAT LENGTH?

**Strips of I-Rod** are available in lengths of five feet, ten feet or one meter (3.28'). 2" I-Rod is available in 8' lengths only.

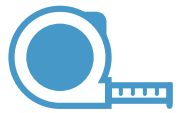

## I-ROD®

### THE MEASUREMENTS YOU'LL NEED:

**X: Diameter of pipe.** Either an exact measurement of the pipe and coating, or the pipe specs such as 8" or 10" API.

**Y: Thread length,** so bolts reach past bottom of support.

**Z: Bolt stock,** so bolts fit through existing mounting holes.

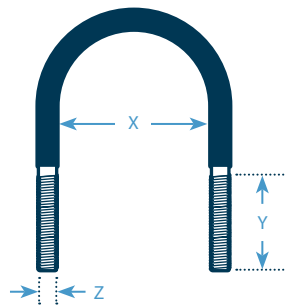

### CHOOSE A COATING FOR THE U-BOLT:

Standard Nu-Bolts come with a long-lasting **hot-dip galvanized** finish. Other options include **316SS** or an ultra-durable **Sermagard** aluminum-ceramic coating for the harshest environments. Nu-Bolts are covered in polyshrink to protect the pipe coating during installation.

## I-ROD® CLIPS

### THE MEASUREMENTS YOU'LL NEED:

**X: Diameter of pipe.** Either an exact measurement of the pipe and coating, or the pipe specs such as 8" or 10" API.

**Y: Width of clamp.** The clip snaps in place over the clamp.

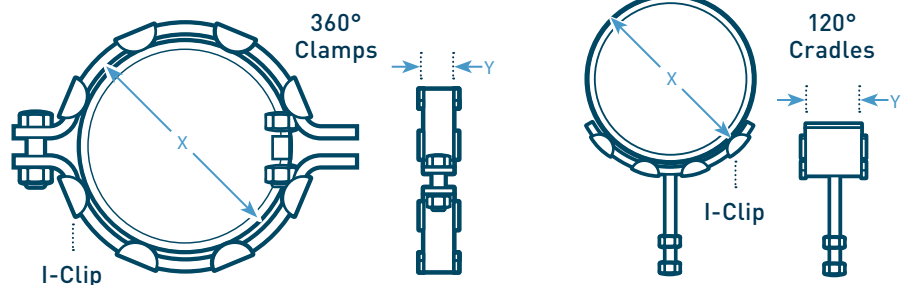

### WHERE TO ORDER?

To order I-Rod, please call us at **+61 3 9310 3515** between 8:30 A.M. and 5 P.M. AEST, or email us at [enquiries@unicc.com.au](mailto:enquiries@unicc.com.au). I-Rod is also available through our regional agents and Deepwater offices worldwide.

### WHAT'S THE LEAD TIME?

Most orders for standard I-Rod are shipped within **two business days**. Larger orders and those with special materials and finishes can require up to **four days**. Call us for more info.

# GALVANIZED NU-BOLT™

[PDF Nu-Bolt TechData Sheet](#)

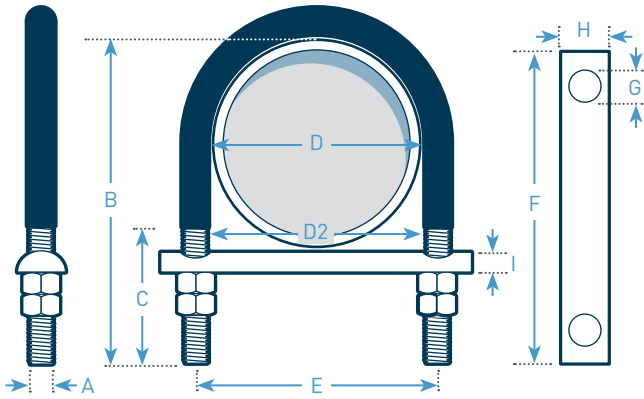

**Includes:**

- U-Bolt with polyshrink
- Four nuts
- Cut and drilled I-Rod®

**Note:** Maximum operating temp for polyshrink is 230° F.

**Note:** Nu-Bolts™ are shipped unassembled; pre-assembled Nu-Bolts™ are available for an additional charge.



With I-Rod® (white)

Min temp: -166° F  
Max temp: 181° F



With I-Rod® HT (amber)

Max temp: 340° F

	A	B	C	D	D2	E	F	G	H	I		
Nominal pipe size	Bolt diameter	U-bolt height	Thread length	Inside gap	Inside gap withoutshrink	Leg center	I-Rod length	I-Rod hole diameter	I-Rod width	I-Rod height	Part number	Part number
1/2"	1/4"	3 1/4"	2 3/8"	13/16"	15/16"	1 3/16"	2 1/2"	3/8"	3/4"	5/16"	NUB0045	NUB0431
1/2"	1/4"	3 1/4"	2 3/8"	1"	1 1/8"	1 3/8"	2 11/16"	3/8"	3/4"	5/16"	NUB1481	NUB1488
1/2"	3/8"	3 1/4"	2 3/8"	13/16"	15/16"	1 5/16"	2 1/2"	1/2"	1"	7/16"	NUB0046	NUB0193
3/4"	1/4"	3 5/16"	2 3/8"	1"	1 1/8"	1 3/8"	3"	3/8"	3/4"	5/16"	NUB0071	NUB0408
3/4"	1/4"	3 5/16"	2 3/8"	1 3/16"	1 5/16"	1 9/16"	3 3/16"	3/8"	3/4"	5/16"	NUB1482	NUB1489
3/4"	3/8"	3 5/16"	2 3/8"	1"	1 1/8"	1 1/2"	3"	1/2"	1"	7/16"	NUB0074	NUB0398
1"	1/4"	3 7/16"	2 3/8"	1 1/4"	1 3/8"	1 5/8"	3"	3/8"	3/4"	5/16"	NUB0047	NUB0198
1"	1/4"	3 7/16"	2 3/8"	1 7/16"	1 9/16"	1 13/16"	3 3/16"	3/8"	3/4"	5/16"	NUB1483	NUB1490
1"	3/8"	3 7/16"	2 3/8"	1 1/4"	1 3/8"	1 3/4"	3"	1/2"	1"	7/16"	NUB0001	NUB0194
1 1/4"	3/8"	3 3/4"	2 1/2"	1 9/16"	1 11/16"	2 1/16"	3 1/2"	1/2"	1"	7/16"	NUB0013	NUB0409
1 1/4"	3/8"	3 3/4"	2 1/2"	1 3/4"	1 7/8"	2 1/4"	3 11/16"	1/2"	1"	7/16"	NUB1484	NUB1491
1 1/2"	3/8"	4"	2 1/2"	1 7/8"	2"	2 3/8"	4"	1/2"	1"	7/16"	NUB0052	NUB0196
1 1/2"	3/8"	4"	2 1/2"	2 1/16"	2 3/16"	2 9/16"	4 3/16"	1/2"	1"	7/16"	NUB1485	NUB1492
2"	3/8"	4 1/2"	2 1/2"	2 5/16"	2 7/16"	2 13/16"	4 1/2"	1/2"	1"	7/16"	NUB0009	NUB0199
2"	3/8"	4 1/2"	2 1/2"	2 1/2"	2 5/8"	3"	4 11/16"	1/2"	1"	7/16"	NUB1486	NUB1493
2 1/2"	1/2"	5 1/4"	3"	2 13/16"	2 15/16"	3 7/16"	5"	5/8"	1"	7/16"	NUB0017	NUB0432
2 1/2"	1/2"	5 1/4"	3"	3"	3 1/8"	3 5/8"	5 3/16"	5/8"	1"	7/16"	NUB1487	NUB1494
3"	1/2"	5 13/16"	3"	3 7/16"	3 9/16"	4 1/16"	6"	5/8"	1"	7/16"	NUB0057	NUB0200
4"	1/2"	6 13/16"	3"	4 7/16"	4 9/16"	5 1/16"	7"	5/8"	1"	7/16"	NUB0060	NUB0195
5"	1/2"	7 13/16"	3"	5 1/2"	5 5/8"	6 1/8"	8"	5/8"	1"	7/16"	NUB0063	NUB0433
6"	5/8"	9 1/2"	3 3/4"	6 5/8"	6 3/4"	7 3/8"	9"	11/16"	1"	7/16"	NUB0064	NUB0067
8"	5/8"	11 1/2"	3 3/4"	8 5/8"	8 3/4"	9 3/8"	11"	11/16"	1"	7/16"	NUB0077	NUB0079
10"	3/4"	13 13/16"	4"	10 3/4"	10 7/8"	11 5/8"	13 1/2"	7/8"	1 1/2"	11/16"	NUB0003	NUB0224
12"	7/8"	16 1/16"	4 1/8"	12 3/4"	12 7/8"	13 3/4"	16"	1"	1 1/2"	11/16"	NUB0085	NUB0225
14"	7/8"	17 5/16"	4 1/8"	14"	14 1/8"	15"	17"	1"	1 1/2"	11/16"	NUB0091	NUB0434
16"	7/8"	19 5/16"	4 1/8"	16"	16 1/8"	17"	19"	1"	1 1/2"	11/16"	NUB0005	NUB0435
18"	1"	21 11/16"	4 3/4"	18"	18 1/8"	19 1/8"	21 1/2"	1 1/8"	1 1/2"	11/16"	NUB0098	NUB0226
20"	1"	23 11/16"	4 3/4"	20"	20 1/8"	21 1/8"	23 1/2"	1 1/8"	1 1/2"	11/16"	NUB0101	NUB0436
24"	1"	27 11/16"	4 3/4"	24"	24 1/8"	25 1/8"	27 1/2"	1 1/8"	1 1/2"	11/16"	NUB0011	NUB0227
28"	1"	31 11/16"	4 3/4"	28"	28 1/8"	29 1/8"	31 1/2"	1 1/8"	1 1/2"	11/16"	NUB0106	NUB0602
30"	1"	33 11/16"	4 3/4"	30"	30 1/8"	31 1/8"	33 1/2"	1 1/8"	1 1/2"	11/16"	NUB0107	NUB0437
36"	1"	39 11/16"	4 3/4"	36"	36 1/8"	37 1/8"	39 1/2"	1 1/8"	1 1/2"	11/16"	NUB0109	NUB0438

# NU-BOLT™ WITH HIGH-TEMPERATURE POLYSHRINK

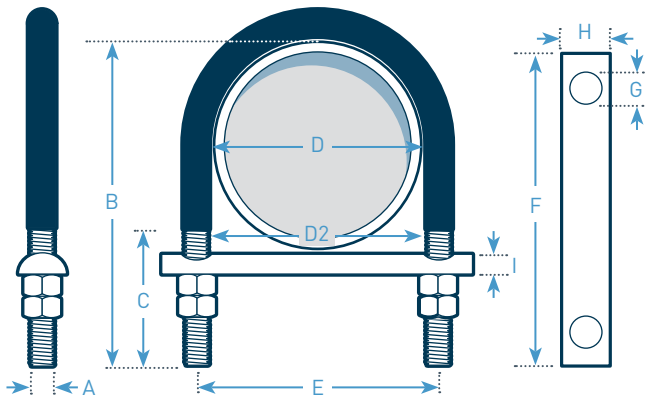

**Includes:**

- U-bolt with polyshrink
- Four nuts
- Cut and drilled I-Rod®

**Note:** Maximum operating temp for HT polyshrink is 428° F.

**Note:** Nu-Bolts™ are shipped unassembled; pre-assembled Nu-Bolts™ are available for an additional charge.



**Galvanized with I-Rod® HT (amber)**

Max temp: 340° F



**316 Stainless with I-Rod® HT (amber)**

Max temp: 340° F

	A	B	C	D	D2	E	F	G	H	I		
Nominal pipe size	Bolt diameter	U-bolt height	Thread length	Inside gap	Inside gap withoutshrink	Leg center	I-Rod length	I-Rod hole diameter	I-Rod width	I-Rod height	Part number	Part number
1/2"	1/4"	3 1/4"	2 3/8"	13/16"	15/16"	1 3/16"	2 1/2"	3/8"	3/4"	5/16"	NUB0895	NUB0925
1/2	1/4	3 1/4	2 3/8	1	1 1/8	1 3/8	2 7/16	3/8	3/4	5/16	NUB1495	NUB1502
1/2	3/8	3 1/4	2 3/8	13/16	15/16	1 5/16	2 1/2	1/2	1	7/16	NUB0896	NUB0926
3/4	1/4	3 5/16	2 3/8	1	1 1/8	1 3/8	3	3/8	3/4	5/16	NUB0897	NUB0927
3/4	1/4	3 5/16	2 3/8	1 3/16	1 5/16	1 9/16	3 3/16	3/8	3/4	5/16	NUB1496	NUB1503
3/4	3/8	3 5/16	2 3/8	1	1 1/8	1 1/2	3	1/2	1	7/16	NUB0898	NUB0928
1	1/4	3 7/16	2 3/8	1 1/4	1 3/8	1 5/8	3	3/8	3/4	5/16	NUB0899	NUB0929
1	1/4	3 7/16	2 3/8	1 7/16	1 9/16	1 13/16	3 3/16	3/8	3/4	5/16	NUB1497	NUB1504
1	3/8	3 7/16	2 3/8	1 1/4	1 3/8	1 3/4	3	1/2	1	7/16	NUB0900	NUB0930
1 1/4	3/8	3 3/4	2 1/2	1 9/16	1 11/16	2 1/16	3 1/2	1/2	1	7/16	NUB0901	NUB0931
1 1/4	3/8	3 3/4	2 1/2	1 3/4	1 7/8	2 1/4	3 11/16	1/2	1	7/16	NUB1498	NUB1505
1 1/2	3/8	4	2 1/2	1 7/8	2	2 3/8	4	1/2	1	7/16	NUB0902	NUB0932
1 1/2	3/8	4	2 1/2	2 1/16	2 3/16	2 9/16	4 3/16	1/2	1	7/16	NUB1499	NUB1506
2	3/8	4 1/2	2 1/2	2 5/16	2 7/16	2 13/16	4 1/2	1/2	1	7/16	NUB0903	NUB0933
2	3/8	4 1/2	2 1/2	2 1/2	2 5/8	3	4 11/16	1/2	1	7/16	NUB1500	NUB1507
2 1/2	1/2	5 1/4	3	2 13/16	2 15/16	3 7/16	5	5/8	1	7/16	NUB0905	NUB0935
2 1/2	1/2	5 1/4	3	3	3 1/8	3 5/8	5 3/16	5/8	1	7/16	NUB1501	NUB1508
3	1/2	5 13/16	3	3 7/16	3 9/16	4 1/16	6	5/8	1	7/16	NUB0906	NUB0937
4	1/2	6 13/16	3	4 7/16	4 9/16	5 1/16	7	5/8	1	7/16	NUB0908	NUB0938
5	1/2	7 13/16	3	5 1/2	5 5/8	6 1/8	8	5/8	1	7/16	NUB0909	NUB0939
6	5/8	9 1/2	3 3/4	6 5/8	6 3/4	7 3/8	9	11/16	1	7/16	NUB0910	NUB0940
8	5/8	11 1/2	3 3/4	8 5/8	8 3/4	9 3/8	11	11/16	1	7/16	NUB0911	NUB0941
10	3/4	13 13/16	4	10 3/4	10 7/8	11 5/8	13 1/2	7/8	1 1/2	11/16	NUB0912	NUB0942
12	7/8	16 1/16	4 1/8	12 3/4	12 7/8	13 3/4	16	1	1 1/2	11/16	NUB0913	NUB0943
14	7/8	17 5/16	4 1/8	14	14 1/8	15	17	1	1 1/2	11/16	NUB0914	NUB0944
16	7/8	19 5/16	4 1/8	16	16 1/8	17	19	1	1 1/2	11/16	NUB0915	NUB0945
18	1	21 11/16	4 3/4	18	18 1/8	19 1/8	21 1/2	1 1/8	1 1/2	11/16	NUB0916	NUB0946
20	1	23 11/16	4 3/4	20	20 1/8	21 1/8	23 1/2	1 1/8	1 1/2	11/16	NUB0917	NUB0947
24	1	27 11/16	4 3/4	24	24 1/8	25 1/8	27 1/2	1 1/8	1 1/2	11/16	NUB0918	NUB0948
28	1	31 11/16	4 3/4	28	28 1/8	29 1/8	31 1/2	1 1/8	1 1/2	11/16	NUB0920	NUB0950
30	1	33 11/16	4 3/4	30	30 1/8	31 1/8	33 1/2	1 1/8	1 1/2	11/16	NUB0921	NUB0951
36	1	39 11/16	4 3/4	36	36 1/8	37 1/8	39 1/2	1 1/8	1 1/2	11/16	NUB0922	NUB0952

# CUT AND DRILLED I-ROD® WITHOUT U-BOLT

[PDF I-Rod TechData Sheet](#)

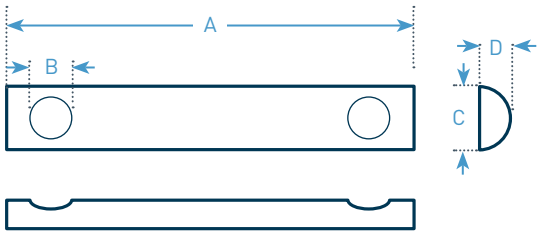

**I-Rod® (white)**

Min temp: -166° F  
Max temp: 181° F



**I-Rod® HT (amber)**

Max temp: 340° F



**I-Rod® PEEK (tan)**

Max temp: 480° F

A B C D

Nominal pipe size	Bolt diameter	I-Rod length	I-Rod hole diameter	I-Rod width	I-Rod height	Part number	Part number	Part number
1/2"	1/4"	2 1/2"	3/8"	3/4"	5/16"	ROD0105	ROD0141	ROD0332
1/2	3/8	2 1/2	1/2	1	7/16	ROD0003	ROD0159	ROD0333
3/4	1/4	3	3/8	3/4	5/16	ROD0013	ROD0148	ROD0334
3/4	3/8	3	1/2	1	7/16	ROD0107	ROD0298	ROD0335
1	1/4	3	3/8	3/4	5/16	ROD0002	ROD0160	ROD0336
1	3/8	3	1/2	1	7/16	ROD0001	ROD0106	ROD0295
1 1/4	3/8	3 1/2	1/2	1	7/16	ROD0076	ROD0232	ROD0337
1 1/2	3/8	4	1/2	1	7/16	ROD0005	ROD0149	ROD0338
2	3/8	4 1/2	1/2	1	7/16	ROD0009	ROD0087	ROD0303
2 1/2	1/2	5	5/8	1	7/16	ROD0022	ROD0233	ROD0339
3	1/2	6	5/8	1	7/16	ROD0012	ROD0090	ROD0340
4	1/2	7	5/8	1	7/16	ROD0014	ROD0096	ROD0341
5	1/2	8	5/8	1	7/16	ROD0015	ROD0299	ROD0342
6	5/8	9	11/16	1	7/16	ROD0074	ROD0101	ROD0343
8	5/8	11	11/16	1	7/16	ROD0017	ROD0104	ROD0344
10	3/4	13 1/2	7/8	1 1/2	11/16	ROD0004	ROD0079	ROD0345
12	7/8	16	1	1 1/2	11/16	ROD0006	ROD0081	ROD0346
14	7/8	17	1	1 1/2	11/16	ROD0007	ROD0243	ROD0347
16	7/8	19	1	1 1/2	11/16	ROD0008	ROD0300	ROD0296
18	1	21 1/2	1 1/8	1 1/2	11/16	ROD0083	ROD0171	ROD0348
20	1	23 1/2	1 1/8	1 1/2	11/16	ROD0010	ROD0140	ROD0349
24	1	27 1/2	1 1/8	1 1/2	11/16	ROD0011	ROD0172	ROD0350
28	1	31 1/2	1 1/8	1 1/2	11/16	ROD0088	ROD0382	ROD0383
30	1	33 1/2	1 1/8	1 1/2	11/16	ROD0092	ROD0301	ROD0351
36	1	39 1/2	1 1/8	1 1/2	11/16	ROD0093	ROD0302	ROD0352

## STAINLESS STEEL AND SERMAGARD™ NU-BOLTS™

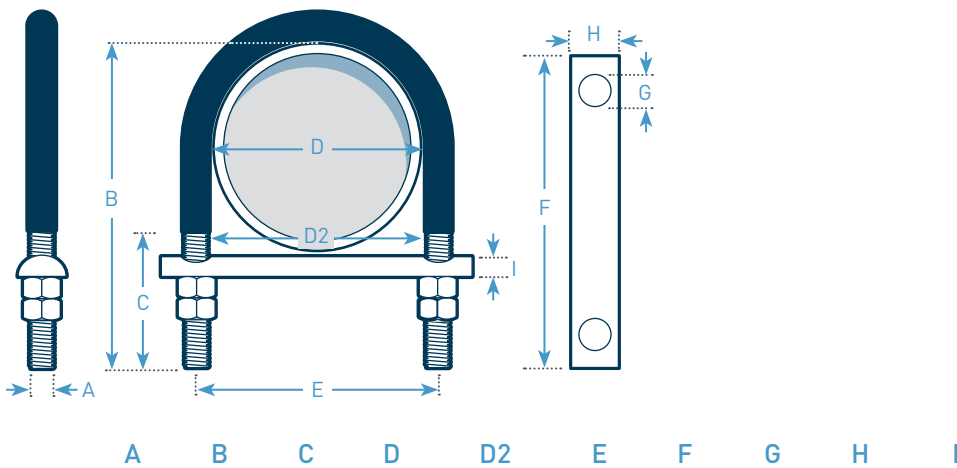

**316 Stainless  
Nu-Bolt™ with  
I-Rod® (white)**

- Stainless U-bolt
- Standard I-Rod®
- Min. temp: -166° F
- Max. temp: 181° F
- Polyshrink
- Four nuts



**Sermagard®  
Nu-Bolt™ with  
I-Rod® (white)**

- Carbon steel U-bolt with Sermagard™
- Standard I-Rod®
- Max. temp: 181° F
- Polyshrink
- Four nuts

Nominal pipe size	Bolt diameter	U-bolt height	Thread length	Inside gap	Inside gap without shrink	Leg center	I-Rod length	I-Rod hole diameter	I-Rod width	I-Rod height	Part number	Part number
1/2"	1/4"	3 1/4"	2 3/8"	13/16"	15/16"	1 3/16"	2 1/2"	3/8"	3/4"	5/16"	NUB0113	NUB0415
1/2	1/4	3 1/4	2 3/8	1	1 1/8	1 3/8	2 11/16	3/8	3/4	5/16	NUB1509	NUB1520
1/2	3/8	3 1/4	2 3/8	13/16	15/16	1 5/16	2 1/2	1/2	1	7/16	NUB0609	NUB0132
3/4	1/4	3 5/16	2 3/8	1	1 1/8	1 3/8	3	3/8	3/4	5/16	NUB0123	NUB0149
3/4	1/4	3 5/16	2 3/8	1 3/16	1 5/16	1 9/16	3 3/16	3/8	3/4	5/16	NUB1510	NUB1521
3/4	3/8	3 5/16	2 3/8	1	1 1/8	1 1/2	3	1/2	1	7/16	NUB0610	NUB0650
1	1/4	3 7/16	2 3/8	1 1/4	1 3/8	1 5/8	3	3/8	3/4	5/16	NUB0114	NUB0491
1	1/4	3 7/16	2 3/8	1 7/16	1 9/16	1 13/16	3 3/16	3/8	3/4	5/16	NUB1511	NUB1522
1	3/8	3 7/16	2 3/8	1 1/4	1 3/8	1 3/4	3	1/2	1	7/16	NUB0038	NUB0133
1 1/2	3/8	4	2 1/2	1 7/8	2	2 3/8	4	1/2	1	7/16	NUB0116	NUB0135
1 1/2	3/8	4	2 1/2	2 1/16	2 3/16	2 9/16	4 3/16	1/2	1	7/16	NUB1512	NUB1523
2	3/8	4 1/2	2 1/2	2 5/16	2 7/16	2 13/16	4 1/2	1/2	1	7/16	NUB0018	NUB0137
2	3/8	4 1/2	2 1/2	2 1/2	2 5/8	3	4 11/16	1/2	1	7/16	NUB1513	NUB1524
2 1/2	1/2	5 1/4	3	2 13/16	2 15/16	3 7/16	5	5/8	1	7/16	NUB0442	NUB0440
2 1/2	1/2	5 1/4	3	3	3 1/8	3 5/8	5 3/16	5/8	1	7/16	NUB1514	NUB1525
3	1/2	5 13/16	3	3 7/16	3 9/16	4 1/16	6	5/8	1	7/16	NUB0119	NUB0012
4	1/2	6 13/16	3	4 7/16	4 9/16	5 1/16	7	5/8	1	7/16	NUB0120	NUB0144
5	1/2	7 13/16	3	5 1/2	5 5/8	6 1/8	8	5/8	1	7/16	NUB0277	NUB0441
6	5/8	9 1/2	3 3/4	6 5/8	6 3/4	7 3/8	9	11/16	1	7/16	NUB0121	NUB0147
8	5/8	11 1/2	3 3/4	8 5/8	8 3/4	9 3/8	11	11/16	1	7/16	NUB0125	NUB0150
10	3/4	13 13/16	4	10 3/4	10 7/8	11 5/8	13 1/2	7/8	1 1/2	11/16	NUB0127	NUB0152
12	7/8	16 1/16	4 1/8	12 3/4	12 7/8	13 3/4	16	1	1 1/2	11/16	NUB0128	NUB0155
14	7/8	17 5/16	4 1/8	14	14 1/8	15	17	1	1 1/2	11/16	NUB0390	NUB0157
16	7/8	19 5/16	4 1/8	16	16 1/8	17	19	1	1 1/2	11/16	NUB0129	NUB0006
18	1	21 11/16	4 3/4	18	18 1/8	19 1/8	21 1/2	1 1/8	1 1/2	11/16	NUB0232	NUB0159
20	1	23 11/16	4 3/4	20	20 1/8	21 1/8	23 1/2	1 1/8	1 1/2	11/16	NUB0130	NUB0160
24	1	27 11/16	4 3/4	24	24 1/8	25 1/8	27 1/2	1 1/8	1 1/2	11/16	NUB0131	NUB0161
30	1	33 11/16	4 3/4	30	30 1/8	31 1/8	33 1/2	1 1/8	1 1/2	11/16	NUB0616	NUB0559



# NON-GRIPPING I-ROD® WITH FLATS AND NU-BOLT™

[PDF How Non-Gripping Nu-Bolts Work](#)

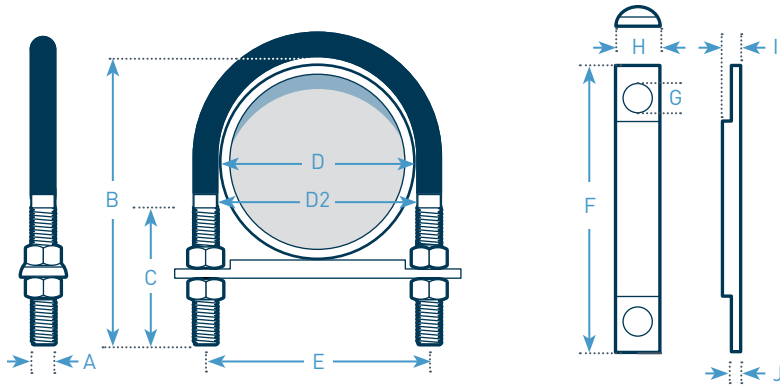

**Non-gripping I-Rod® (white)**

- Min temp: -166° F
- Max temp: 181° F

**Non-gripping Nu-Bolt™ (white)**

- Galvanized U-bolt
- Standard I-Rod®
- 181° F max temp
- Polyshrink
- Four nuts

A B C D D2 E F G H I J

Nominal pipe size	Bolt diameter	U-bolt height	Thread length	Inside gap	Inside gap without shrink	Leg center	I-Rod length	I-Rod hole diameter	I-Rod width	I-Rod height	Tab thickness	Part number	Part number
1/2"	1/4"	3 1/4"	2 3/8"	13/16"	15/16"	1 3/16"	2 1/2"	3/8"	3/4"	5/16"	3/16"	ROD0391	NUB0563
3/4	1/4	3 5/16	2 3/8	1	1 1/8	1 3/8	3	3/8	3/4	5/16	3/16	ROD0392	NUB0564
3/4	3/8	3 5/16	2 3/8	1	1 1/8	1 1/2	3	1/2	1	7/16	1/4	ROD0425	NUB0565
1	1/4	3 7/16	2 3/8	1 1/4	1 3/8	1 5/8	3	3/8	3/4	5/16	3/16	ROD0393	NUB0566
1	3/8	3 7/16	2 3/8	1 1/4	1 3/8	1 3/4	3	1/2	1	7/16	1/4	ROD0394	NUB0567
1 1/2	3/8	4	2 1/2	1 7/8	2	2 3/8	4	1/2	1	7/16	1/4	ROD0396	NUB0568
2	3/8	4 1/2	2 1/2	2 5/16	2 7/16	2 13/16	4 1/2	1/2	1	7/16	1/4	ROD0397	NUB0569
2 1/2	1/2	5 1/4	3	2 13/16	2 15/16	3 7/16	5	5/8	1	7/16	1/4	ROD0398	NUB0570
3	1/2	5 13/16	3	3 7/16	3 9/16	4 1/16	6	5/8	1	7/16	1/4	ROD0399	NUB0571
4	1/2	6 13/16	3	4 7/16	4 9/16	5 1/16	7	5/8	1	7/16	1/4	ROD0400	NUB0572
5	1/2	7 13/16	3	5 1/2	5 5/8	6 1/8	8	5/8	1	7/16	1/4	ROD0401	NUB0573
6	5/8	9 1/2	3 3/4	6 5/8	6 3/4	7 3/8	9	11/16	1	7/16	1/4	ROD0402	NUB0560
8	5/8	11 1/2	3 3/4	8 5/8	8 3/4	9 3/8	11	11/16	1	7/16	1/4	ROD0403	NUB0574
10	3/4	13 13/16	4	10 3/4	10 7/8	11 5/8	13 1/2	7/8	1 1/2	11/16	3/16	ROD0404	NUB0575
12	7/8	16 1/16	4 1/8	12 3/4	12 7/8	13 3/4	16	1	1 1/2	11/16	3/16	ROD0405	NUB0576
14	7/8	17 5/16	4 1/8	14	14 1/8	15	17	1	1 1/2	11/16	3/16	ROD0406	NUB0577
16	7/8	19 5/16	4 1/8	16	16 1/8	17	19	1	1 1/2	11/16	3/16	ROD0407	NUB0561
18	1	21 11/16	4 3/4	18	18 1/8	19 1/8	21 1/2	1 1/8	1 1/2	11/16	3/16	ROD0408	NUB0578
20	1	23 11/16	4 3/4	20	20 1/8	21 1/8	23 1/2	1 1/8	1 1/2	11/16	3/16	ROD0409	NUB0579
24	1	27 11/16	4 3/4	24	24 1/8	25 1/8	27 1/2	1 1/8	1 1/2	11/16	3/16	ROD0410	NUB0562
28	1	31 11/16	4 3/4	28	28 1/8	29 1/8	31 1/2	1 1/8	1 1/2	11/16	3/16	ROD0412	NUB0722
30	1	33 11/16	4 3/4	30	30 1/8	31 1/8	33 1/2	1 1/8	1 1/2	11/16	3/16	ROD0413	NUB0580
36	1	39 11/16	4 3/4	36	36 1/8	37 1/8	39 1/2	1 1/8	1 1/2	11/16	3/16	ROD0414	NUB0581



## NON-GRIPPING I-ROD® XL WITH FLATS AND NU-BOLT™ XL

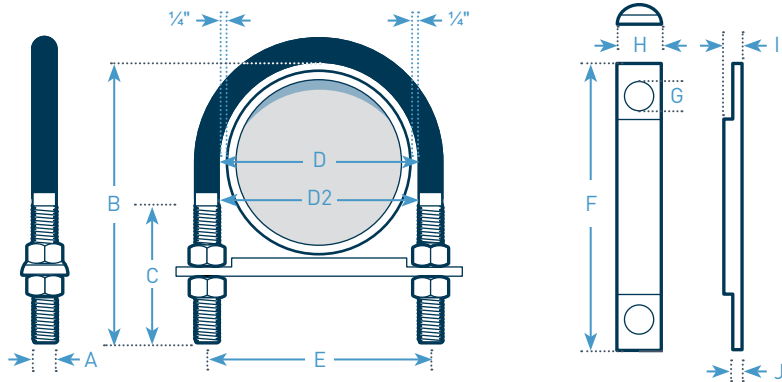

Non-gripping  
I-Rod® XL  
(white)

- Min temp: -166° F
- Max temp: 181° F



Non-gripping  
Nu-Bolt™ XL  
(white)

- Galvanized U-bolt
- Standard I-Rod®
- 181° F max temp
- Polyshrink
- Four nuts

	A	B	C	D	D2	E	F	G	H	I	J		
Nominal pipe size	Bolt diameter	U-bolt height	Thread length	Inside gap	Inside gap without shrink	Leg center	I-Rod length	I-Rod hole diameter	I-Rod width	I-Rod height	Tab thickness	Part number	Part number
1/2"	1/4"	3 1/4"	2 3/8"	1 5/16"	1 7/16"	1 11/16"	3"	3/8"	3/4"	5/16"	3/16"	ROD0632	NUB1458
3/4	1/4	3 5/16"	2 3/8"	1 1/2"	1 5/8"	1 7/8"	3 1/2"	3/8"	3/4"	5/16"	3/16"	ROD0633	NUB1459
3/4	3/8	3 5/16"	2 3/8"	1 1/2"	1 5/8"	2	3 1/2"	1/2"	1	7/16"	1/4"	ROD0634	NUB1460
1	1/4	3 7/16"	2 3/8"	1 3/4"	1 7/8"	2 1/8"	3 1/2"	3/8"	3/4"	5/16"	3/16"	ROD0635	NUB1461
1	3/8	3 7/16"	2 3/8"	1 3/4"	1 7/8"	2 1/4"	3 1/2"	1/2"	1	7/16"	1/4"	ROD0636	NUB1462
1 1/2	3/8	4	2 1/2"	2 3/8"	2 1/2"	2 7/8"	4 1/2"	1/2"	1	7/16"	1/4"	ROD0637	NUB1463
2	3/8	4 1/2"	2 1/2"	2 13/16"	2 15/16"	3 5/16"	5	1/2"	1	7/16"	1/4"	ROD0638	NUB1464
2 1/2	1/2	5 1/4"	3	3 5/16"	3 7/16"	3 15/16"	5 1/2"	5/8"	1	7/16"	1/4"	ROD0639	NUB1465
3	1/2	5 13/16"	3	3 15/16"	4 1/16"	4 9/16"	6 1/2"	5/8"	1	7/16"	1/4"	ROD0640	NUB1466
4	1/2	6 13/16"	3	4 15/16"	5 1/16"	5 9/16"	7 1/2"	5/8"	1	7/16"	1/4"	ROD0641	NUB1467
5	1/2	7 13/16"	3	6	6 1/8"	6 5/8"	8 1/2"	5/8"	1	7/16"	1/4"	ROD0642	NUB1468
6	5/8	9 1/2"	3 3/4"	7 1/8"	7 1/4"	7 7/8"	9 1/2"	11/16"	1	7/16"	1/4"	ROD0643	NUB1469
8	5/8	11 1/2"	3 3/4"	9 1/8"	9 1/4"	9 7/8"	11 1/2"	11/16"	1	7/16"	1/4"	ROD0644	NUB1470
10	3/4	13 13/16"	4	11 1/4"	11 3/8"	12 1/8"	14	7/8"	1 1/2"	11/16"	3/16"	ROD0645	NUB1471
12	7/8	16 1/16"	4 1/8"	13 1/4"	13 3/8"	14 1/4"	16 1/2"	1	1 1/2"	11/16"	3/16"	ROD0646	NUB1472
14	7/8	17 5/16"	4 1/8"	14 1/2"	14 5/8"	15 1/2"	17 1/2"	1	1 1/2"	11/16"	3/16"	ROD0647	NUB1473
16	7/8	19 5/16"	4 1/8"	16 1/2"	16 5/8"	17 1/2"	19 1/2"	1	1 1/2"	11/16"	3/16"	ROD0648	NUB1474
18	1	21 11/16"	4 3/4"	18 1/2"	18 5/8"	19 5/8"	22	1 1/8"	1 1/2"	11/16"	3/16"	ROD0649	NUB1475
20	1	23 11/16"	4 3/4"	20 1/2"	20 5/8"	21 5/8"	24	1 1/8"	1 1/2"	11/16"	3/16"	ROD0650	NUB1476
24	1	27 11/16"	4 3/4"	24 1/2"	24 5/8"	25 5/8"	28	1 1/8"	1 1/2"	11/16"	3/16"	ROD0651	NUB1477
28	1	31 11/16"	4 3/4"	28 1/2"	28 5/8"	29 5/8"	32	1 1/8"	1 1/2"	11/16"	3/16"	ROD0652	NUB1478
30	1	33 11/16"	4 3/4"	30 1/2"	30 5/8"	31 5/8"	34	1 1/8"	1 1/2"	11/16"	3/16"	ROD0653	NUB1479
36	1	39 11/16"	4 3/4"	36 1/2"	36 5/8"	37 5/8"	40	1 1/8"	1 1/2"	11/16"	3/16"	ROD0654	NUB1480

## I-ROD® STRIPS

I-Rod® by the foot is available in lengths of five feet, ten feet or one meter (3.28').

[PDF How to Order I-Rod](#)



I-Rod® (white)

Min temp: -166° F  
Max temp: 181° F



I-Rod® HT (amber)

Max temp 340° F



PEEK (tan)

Up to 480° F

I-Rod width	Height in inches	Length in feet	Part number	Part number	Part number
3/4"	5/16"	5'	IRD0056	IRD0357	IRD0360
1	7/16	5	IRD0034	IRD0233	IRD0344
1 ½	11/16	5	IRD0045	IRD0234	IRD0354
3/4	5/16	10	IRD0220	IRD0228	IRD0361
1	7/16	10	IRD0156	IRD0358	IRD0362
1 ½	11/16	10	IRD0371	IRD0359	IRD0363
3/4	5/16	3.28	IRD0055	IRD0364	IRD0365
1	7/16	3.28	IRD0030	IRD0337	IRD0338
1 ½	11/16	3.28	IRD0043	IRD0336	IRD0366

## DETERMINING I-ROD® LOAD VALUES WEIGHT (LB) PER FOOT OF PIPING FULL OF WATER

The table shows conservative estimates of the total weight of a foot of pipe filled with water. Multiply this number by your support spacing to get total weight loading, then select number of I-Rods® you'll need. Use 1-inch I-Rods® if pipe diameter is 8" or less; 1 ½ -inch I-Rod® is for piping 10" or greater in diameter. Do not mix rod sizes.

Nominal pipe size	Outside diameter	Std	Sch 40	X-Strong	Sch 80	Sch 120	Sch 140	Sch 160	X-Strong
2"	2.375"	6	6	7	7			9	11
3	3.5	12	12	14	14			18	23
4	4.5	18	18	22	22	26		29	34
6	6.625	33	34	44	44	51		60	68
8	8.625	51	54	69	69	86	93	100	97
10	10.75	76	80	94	104	129	143	155	143
12	12.75	104	110	121	144	181	195	215	181
14	14	122	131	140	173	217	237	255	
16	16	151	171	171	224	280	310	332	
18	18	183	216	205	282	354	384	418	
20	20	217	261	242	346	432	447	514	
24	24	294	370	325	494	625	678	737	
26	26	337		370					
28	28	383		419					
30	30	431		470					
36	36	593	731	639					
42	42	780		834					

### Maximum loading for each I-Rod®

1 inch I-Rod®: **8,000 lb**  
1 ½ inch I-Rod®: **10,000 lb**

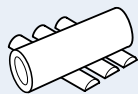

Use up to three rods to support desired weight.

## U-BOLTS WITH POLYSHRINK

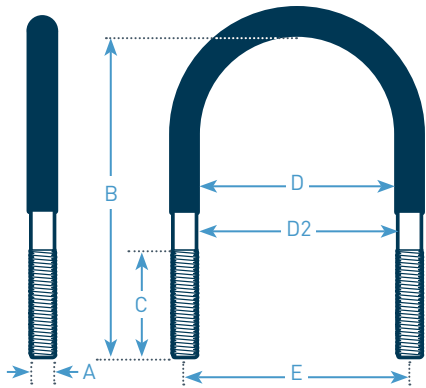

Note: Please see page 15 to order nuts.

Note: Maximum operating temp for polyshrink is 230° F.



	A	B	C	D	D2	E			
Nominal pipe size	Bolt diameter	U-bolt height	Thread length	Inside gap	Inside gap without shrink	Leg center	Part number	Part number	Part number
1/2"	1/4"	3 1/4"	2 3/8"	13/16"	15/16"	1 3/16"	UBT0040	UBT0438	UBT0321
1/2	1/4	3 1/4	2 3/8	1	1 1/8	1 3/8	UBT0950	UBT0957	UBT0964
1/2	3/8	3 1/4	2 3/8	13/16	15/16	1 5/16	UBT0168	UBT0464	UBT0140
3/4	1/4	3 5/16	2 3/8	1	1 1/8	1 3/8	UBT0023	UBT0422	UBT0149
3/4	1/4	3 5/16	2 3/8	1 3/16	1 5/16	1 9/16	UBT0951	UBT0958	UBT0965
3/4	3/8	3 5/16	2 3/8	1	1 1/8	1 1/2	UBT0198	UBT0465	UBT0256
1	1/4	3 7/16	2 3/8	1 1/4	1 3/8	1 5/8	UBT0033	UBT0423	UBT0035
1	1/4	3 7/16	2 3/8	1 7/16	1 9/16	1 13/16	UBT0952	UBT0959	UBT0966
1	3/8	3 7/16	2 3/8	1 1/4	1 3/8	1 3/4	UBT0036	UBT0249	UBT0039
1 1/4	3/8	3 3/4	2 1/2	1 9/16	1 11/16	2 1/16	UBT0004	UBT0487	UBT0461
1 1/4	3/8	3 3/4	2 1/2	1 3/4	1 7/8	2 1/4	UBT0953	UBT0960	UBT0967
1 1/2	3/8	4	2 1/2	1 7/8	2	2 3/8	UBT0002	UBT0250	UBT0003
1 1/2	3/8	4	2 1/2	2 1/16	2 3/16	2 9/16	UBT0954	UBT0961	UBT0968
2	3/8	4 1/2	2 1/2	2 5/16	2 7/16	2 13/16	UBT0015	UBT0012	UBT0013
2	3/8	4 1/2	2 1/2	2 1/2	2 5/8	3	UBT0955	UBT0962	UBT0969
2 1/2	1/2	5 1/4	3	2 13/16	2 15/16	3 7/16	UBT0019	UBT0496	UBT0482
2 1/2	1/2	5 1/4	3	3	3 1/8	3 5/8	UBT0956	UBT0963	UBT0970
3	1/2	5 13/16	3	3 7/16	3 9/16	4 1/16	UBT0020	UBT0424	UBT0021
4	1/2	6 13/16	3	4 7/16	4 9/16	5 1/16	UBT0026	UBT0381	UBT0025
5	1/2	7 13/16	3	5 1/2	5 5/8	6 1/8	UBT0027	UBT0509	UBT0261
6	5/8	9 1/2	3 3/4	6 5/8	6 3/4	7 3/8	UBT0029	UBT0425	UBT0030
8	5/8	11 1/2	3 3/4	8 5/8	8 3/4	9 3/8	UBT0032	UBT0447	UBT0263
10	3/4	13 13/16	4	10 3/4	10 7/8	11 5/8	UBT0205	UBT0426	UBT0001
12	7/8	16 1/16	4 1/8	12 3/4	12 7/8	13 3/4	UBT0208	UBT0448	UBT0006
14	7/8	17 5/16	4 1/8	14	14 1/8	15	UBT0007	UBT0449	UBT0486
16	7/8	19 5/16	4 1/8	16	16 1/8	17	UBT0216	UBT0451	UBT0008
18	1	21 11/16	4 3/4	18	18 1/8	19 1/8	UBT0221	UBT0489	UBT0011
20	1	23 11/16	4 3/4	20	20 1/8	21 1/8	UBT0017	UBT0252	UBT0018
24	1	27 11/16	4 3/4	24	24 1/8	25 1/8	UBT0228	UBT0253	UBT0267
28	1	31 11/16	4 3/4	28	28 1/8	29 1/8	UBT0458	UBT0512	UBT0544
30	1	33 11/16	4 3/4	30	30 1/8	31 1/8	UBT0233	UBT0513	UBT0483
36	1	39 11/16	4 3/4	36	36 1/8	37 1/8	UBT0236	UBT0514	UBT0545

## U-BOLTS WITH HIGH-TEMPERATURE POLYSHRINK

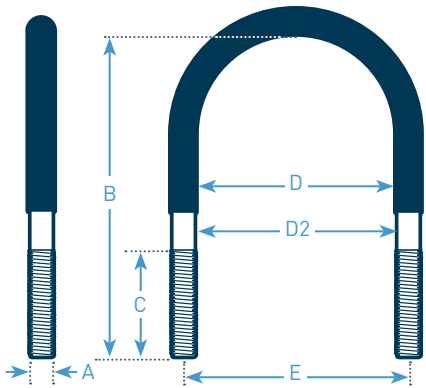

Note: Please see page 15 to order nuts.

Note: Maximum operating temp for HT polyshrink is 428° F.



	A	B	C	D	D2	E		
Nominal pipe size	Bolt diameter	U-bolt height	Thread length	Inside gap	Inside gap without shrink	Leg center	Part number	Part number
1/2"	1/4"	3 1/4"	2 3/8"	13/16"	15/16"	1 3/16"	UBT0752	UBT0722
1/2	1/4	3 1/4	2 3/8	1	1 1/8	1 3/8	UBT0971	UBT0978
1/2	3/8	3 1/4	2 3/8	13/16	15/16	1 5/16	UBT0753	UBT0723
3/4	1/4	3 5/16	2 3/8	1	1 1/8	1 3/8	UBT0754	UBT0724
3/4	1/4	3 5/16	2 3/8	1 3/16	1 5/16	1 9/16	UBT0972	UBT0979
3/4	3/8	3 5/16	2 3/8	1	1 1/8	1 1/2	UBT0755	UBT0725
1	1/4	3 7/16	2 3/8	1 1/4	1 3/8	1 5/8	UBT0756	UBT0726
1	1/4	3 7/16	2 3/8	1 7/16	1 9/16	1 13/16	UBT0973	UBT0980
1	3/8	3 7/16	2 3/8	1 1/4	1 3/8	1 3/4	UBT0757	UBT0727
1 1/4	3/8	3 3/4	2 1/2	1 9/16	1 11/16	2 1/16	UBT0758	UBT0728
1 1/4	3/8	3 3/4	2 1/2	1 3/4	1 7/8	2 1/4	UBT0974	UBT0981
1 1/2	3/8	4	2 1/2	1 7/8	2	2 3/8	UBT0759	UBT0729
1 1/2	3/8	4	2 1/2	2 1/16	2 3/16	2 9/16	UBT0975	UBT0982
2	3/8	4 1/2	2 1/2	2 5/16	2 7/16	2 13/16	UBT0760	UBT0730
2	3/8	4 1/2	2 1/2	2 1/2	2 5/8	3	UBT0976	UBT0983
2 1/2	1/2	5 1/4	3	2 13/16	2 15/16	3 7/16	UBT0762	UBT0732
2 1/2	1/2	5 1/4	3	3	3 1/8	3 5/8	UBT0977	UBT0984
3	1/2	5 13/16	3	3 7/16	3 9/16	4 1/16	UBT0763	UBT0733
4	1/2	6 13/16	3	4 7/16	4 9/16	5 1/16	UBT0765	UBT0735
5	1/2	7 13/16	3	5 1/2	5 5/8	6 1/8	UBT0766	UBT0736
6	5/8	9 1/2	3 3/4	6 5/8	6 3/4	7 3/8	UBT0767	UBT0737
8	5/8	11 1/2	3 3/4	8 5/8	8 3/4	9 3/8	UBT0768	UBT0738
10	3/4	13 13/16	4	10 3/4	10 7/8	11 5/8	UBT0769	UBT0739
12	7/8	16 1/16	4 1/8	12 3/4	12 7/8	13 3/4	UBT0770	UBT0740
14	7/8	17 5/16	4 1/8	14	14 1/8	15	UBT0771	UBT0741
16	7/8	19 5/16	4 1/8	16	16 1/8	17	UBT0772	UBT0742
18	1	21 11/16	4 3/4	18	18 1/8	19 1/8	UBT0773	UBT0743
20	1	23 11/16	4 3/4	20	20 1/8	21 1/8	UBT0774	UBT0744
24	1	27 11/16	4 3/4	24	24 1/8	25 1/8	UBT0775	UBT0745
28	1	31 11/16	4 3/4	28	28 1/8	29 1/8	UBT0776	UBT0747
30	1	33 11/16	4 3/4	30	30 1/8	31 1/8	UBT0778	UBT0748
36	1	39 11/16	4 3/4	36	36 1/8	37 1/8	UBT0779	UBT0749

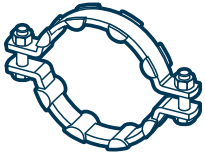

## I-ROD® CLIPS FOR 360° CLAMPS

[PDF I-Rod Clips TechData Sheet](#)

(Contact us for pricing on custom I-Rod® Clips)

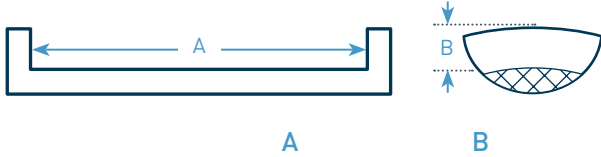

**I-Rod® (white)**

Min temp: -166° F  
Max temp: 181° F



**I-Rod® HT (amber)**

Max temp: 340° F

Nominal pipe size	Inside gap	Internal radius	Recommended clips per clamp	Part number	Part number
3"	1"	2"	4	IRD0190	IRD0280
4	1 ¼	2 ½	4	IRD0191	IRD0281
6	1 ½	3 9/16	6	IRD0192	IRD0169
8	1 ½	4 9/16	8	IRD0193	IRD0282
10	2	5 5/8	8	IRD0194	IRD0283
12	2	None	8	IRD0195	IRD0284
14	2 ½	None	8	IRD0196	IRD0285
16-20	2 ½	None	10	IRD0196	IRD0285
24	3	None	12	IRD0200	IRD0170
26-28	3	None	14	IRD0200	IRD0170
30-36	4	None	16	IRD0202	IRD0224

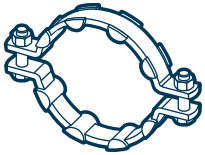

## METRIC CLIPS FOR 360° CLAMPS

(Fits Carpenter & Patterson 360° clamps)



**I-Rod® (white)**

Min temp: -166° F  
Max temp: 181° F



**I-Rod® HT (amber)**

Max temp: 340° F

Nominal pipe size	Inside gap	Recommended clips per clamp	Part number	Part number
80 mm	40 mm	4	IRD0259	IRD0298
100	50	4	IRD0260	IRD0299
150	65	6	IRD0261	IRD0300
200	65	8	IRD0262	IRD0271
250	65	8	IRD0263	IRD0301
300	80	8	IRD0264	IRD0302
350	90	8	IRD0265	IRD0303
400-500	90	10	IRD0265	IRD0303
550, 600	90	12	IRD0265	IRD0303
650, 700	110	14	IRD0266	IRD0306
750, 800	110	16	IRD0266	IRD0306

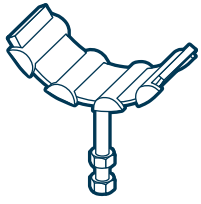

## I-ROD® CLIPS FOR 120° CRADLES

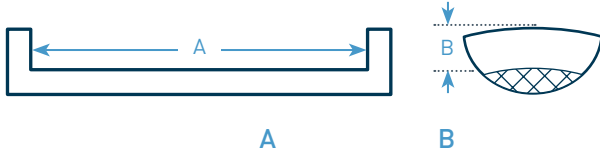

### I-Rod® Clips

Min temp: -166° F  
Max temp: 181° F



### I-Rod® HT Clips

Max temp: 340° F

Nominal pipe size	Inside gap	Internal radius	Recommended clips per cradle	Part number	Part number
3"	4"	2"	2	IRD0204	IRD0274
4	4	2 ½	2	IRD0205	IRD0275
6	4	3 9/16	4	IRD0206	IRD0276
6	6	3 9/16	N/A	IRD0314	IRD0276
8	4	4 9/16	4	IRD0207	IRD0277
10	4	5 5/8	4	IRD0208	IRD0278
12-14	4	None	4	IRD0202	IRD0224
16-18	4	None	6	IRD0202	IRD0224
20-24	6	None	6	IRD0213	IRD0279
26-36	6	None	8	IRD0213	IRD0279
12-30	8	None	N/A	IRD0312	

## NOTCHED I-ROD® BY THE FOOT

[PDF Notched I-Rod TechData Sheet](#)

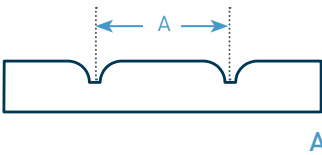
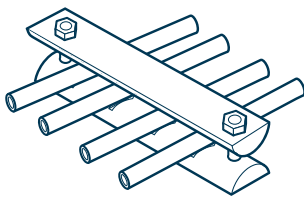

### I-Rod® (white)

Max temp: 181° F

Rod width	Notch space	Part number
3/4"	1/2"	NRD0012
3/4	5/8	NRD0013
3/4	3/4	NRD0014
3/4	7/8	NRD0015

## DEEPWATER LOCATIONS

I-Rod® products are manufactured at Deepwater's headquarters in Houston and can be ordered through their distributor Universal Corrosion Coatings by calling on +61 3 9310 3515 or emailing at [enquiries@unicc.com.au](mailto:enquiries@unicc.com.au)

**Note:** The maximum length for a strip of notched I-Rod® is three feet.

## HEAVY HEX NUTS



	Galvanized	316 SS	Sermagard™
Bolt diameter	Part number	Part number	Part number
1/4"	FAS0044	FAS0051	FAS0056
3/8	FAS0045	FAS0052	FAS0058
1/2	FAS0046	FAS0053	FAS0055
5/8	FAS0047	FAS0353	FAS0060
3/4	FAS0048	FAS0231	FAS0057
7/8	FAS0049	FAS0232	FAS0061
1	FAS0050	FAS0225	FAS0059

## WASHERS



	Galvanized	316 SS	Sermagard™
Bolt diameter	Part number	Part number	Part number
1/4"	FAS0155	FAS0142	FAS0130
3/8	FAS0159	FAS0145	FAS0233
1/2	FAS0154	FAS0307	FAS0129
5/8	FAS0162	FAS0410	FAS0133
3/4	FAS0157	FAS0411	FAS0132
7/8	FAS0164	FAS0412	FAS0134
1	FAS0153	FAS0149	FAS0128

## I-ROD® ADHESIVE

Permanently installs I-Rod® strips.

**Note:** Linear feet per 13.5 oz / 400 ml dual cartridge with 1:1 adhesive mix ratio.

**Attention:** Storage temperature between 46°F and 70°F. Application temperature between 46°F and 110°F.



Substrate	I-Rod® size			Bond thickness	Sq. in. per cartridge	Part number
	3/4"	1"	1 1/2"			
Concrete	21'	16'	10'	0.125"	195 sq. in.	IRD0407
Steel*	64'	50'	32'	0.04"	610 sq. in.	IRD0407

\*Painted, galvanized, or bare finish

[PDF Adhesive Installation Procedure](#)

## DOUBLE-SIDED TAPE

For keeping I-Rod® in place during installation.



Tape width	Length per roll	Part no. (one roll)
1"	100'	MFR0008
1.5"	100'	MFR0009

## APPLICATOR GUNS

For dual cartridges.



Part number

IRD0409 (shown)

Heavy duty

## NOZZLES

(Sold in bags of 10\*)  
Mixes cartridge contents.



Part number

IRD0408

\*Two nozzles recommended per cartridge.



## NU-BOLT™ TORQUE VALUES

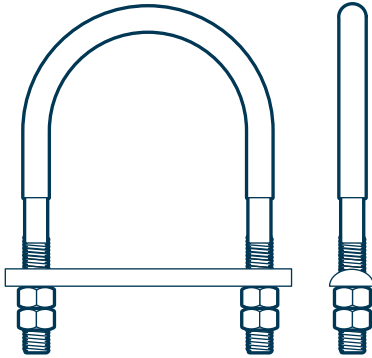

**Thickness Range:** 1" to 1½" I-Rod®

**Material:** I-Rod® proprietary thermoplastic material, carbon steel U-bolt and four finished hex nuts.

**Service:** Recommended for pipes vulnerable to crevice corrosion and to support and guide heavy loads. Often employed in power, process plant and marine service.

**Approvals:** Complies with Federal Specification A-A1192A (Type 24), WW-H-171-E (Type 24), ANSI/MSS SP-69 and MSS SP-58 (Type 24)

**Maximum Loading for each I-Rod®:**

1" I-Rod®: 8,000 lb

1½" I-Rod® HT: 10,000 lb

Use up to three rods to support desired weight.

**Note:** It is assumed that the U-Bolts are not greased. The torque values on this sheet are general recommendations. For more specific calculations, contact us.

**Assumed coefficients of friction vs dry steel:**

I-Rod®: 0.25

I-Rod® HT: 0.42

PEEK: 0.4

**Assumed coefficients of friction on threads:**

HDG 0.15

316SS: 0.17

Sermaguard: 0.12

### Recommended Torque Values (lb-ft)

Bolt Diameter	HDG I-Rod	HDG I-Rod HT	HDG PEEK	316SS I-Rod	316SS I-Rod HT	316SS PEEK	Sermaguard I-Rod	Sermaguard I-Rod HT	Sermaguard PEEK
1/4"	3	5	5	3	5	5	3	5	5
3/8	6	9	9	7	9	9	6	9	8
1/2	15	21	21	15	22	21	14	21	20
5/8	29	42	40	30	43	41	27	40	38
3/4	50	72	69	51	73	71	47	69	66
7/8	79	114	109	82	116	112	74	109	105
1	117	170	163	122	174	168	111	163	157

## RECOMMENDING I-ROD® / NU-BOLT™ PRODUCTS BASED ON TEMPERATURE

Nu-Bolt® assemblies have two polymer components: The pipe support, and the U-Bolt Coating. There are three I-Rod® materials available, and three possible U-Bolt options. Choosing the right Nu-Bolt® for your application can be tricky.

Using these materials at temperatures outside of their rated range will result in loss of strength (softening and melting), cracking and ultimately lead to failure.

The following tables summarize key points and tested data for the materials. If no data is listed, it has not been tested. In addition, some materials may perform outside of these boundaries, but they are not rated, or proven to do so.

**Table 1: Pipe Support Materials**

Pipe Support Material	Temperature Notes	U-Bolt Coating Material	Temperature Notes
I-Rod (White)	For cryogenic and normal atmospheric temperature service	Bare U-Bolt	For cryogenic and extremely high temperature service
I-Rod HT (Amber)	For high temperature service	1.5	Medium temperature service
I-Rod PEEK (Tan)	For high strength, high temperature service	HT Shrink	For high temperature service

**Table 2: Nu-Bolt Polymer Material Temperature Limits**

Material	Max. Excursion Temp. (melt)	Max. Continuous Temp.	Min. Continuous Temp.
I-Rod (White)	For cryogenic and normal atmospheric temperature service		
I-Rod HT (Amber)	210° C / 410° F	171° C / 340° F	
I-Rod PEEK (Tan)	340° C / 644° F	249° C / 480° F	
Polyolefin (Black, thick)		110° C / 230° F	-55° C / -67° F
HT Shrink (black, thin)		220° C / 428° F	-55° C / -67° F
I-Rod Adhesive	100° C / 212° F	22-50° C	-40° C

# I-ROD® INSTALLATION

## TIPS

Deepwater does not provide installation of I-Rod® assemblies. We also do not suggest that there's a certain correct I-Rod® installation process, as local codes, specifications and procedures for each operator and location should always be followed.

If piping has evidence of corrosion, a non-destructive evaluation of the pipe's integrity should be provided by a qualified piping engineer before attempting to lift it from the support. Here are a few tips for installing I-Rod® to help maximize its utility and durability:

**1**

**Use the correct size I-Rod® for the pipe you're supporting.**

I-Rod® comes in three widths: ¾", 1" and 1½". Refer to load value specifications in the table on page 3.

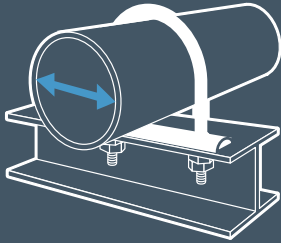

**5**

**Clean the surface if you're using double-sided tape or adhesive.**

Clean the pipe support surface before applying tape or adhesive to hold I-Rod® in place. (Tape and adhesive are on page 14.)

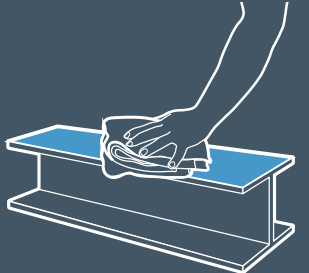

**2**

**Use the correct I-Rod® material for your operating temperature.**

I-Rod® thermoplastic is rated for continuous temperatures up to 181° F, I-Rod® HT® is rated up to 340° F and PEEK is rated up to 480° F.

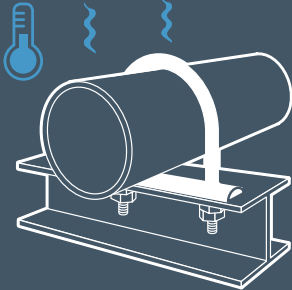

**6**

**The rounded I-Rod® surface must be in contact with the pipe.**

The rounded edge of I-Rod® minimizes the contact area, which prevents corrosion; pipe contact with the flat side cancels the main benefit of I-Rod®.

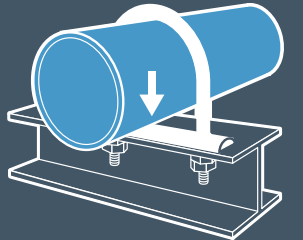

**3**

**Use the correct number of I-Rod® strips.**

Up to three strips can be used to achieve proper weight loading. Refer to load value specifications in the table on page 3.

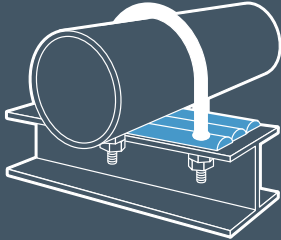

**7**

**Lock the Nu-Bolts™.**

Secure Nu-Bolts™ using the two sets of nuts provided. After tightening the first nut, thread a second one onto the same shaft and tighten it down to lock the nuts.

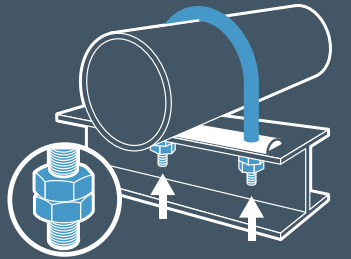

**4**

**Where possible, there should be metal beneath the I-Rod®.**

I-Rod® should be installed with rigid metal backing instead of directly on concrete, where irregular surfaces can cause uneven weight loads.

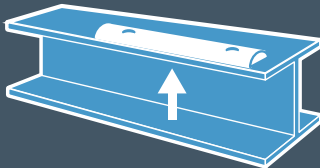

**8**

**Add nut on top for non-gripping applications.**

Slide Nu-Bolt™ over pipe and thread a nut onto each shaft before placing through holes in I-Rod®. Adjust nut heights for desired clearance. Place nuts on bottom and tighten.

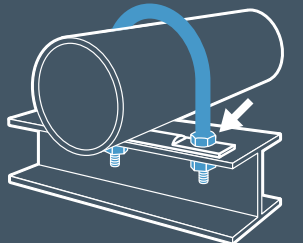

# AUTHENTICITY

MAKE SURE YOUR I-ROD® IS AUTHENTIC

## I-ROD® VS THE COMPETITION:

### I-Rod® is stronger at any temperature

I-Rod® is superior to imitation materials throughout the entire range from extreme cold to extreme heat.

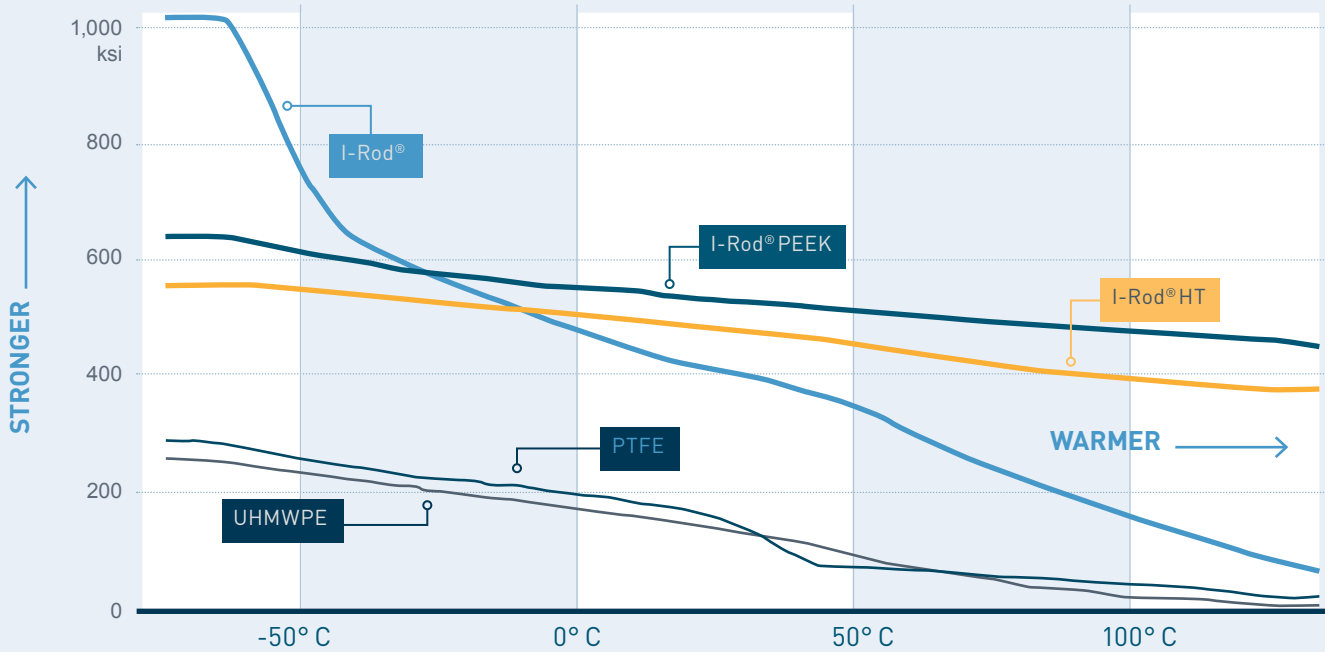

## THE PROBLEM WITH CHEAP IMITATIONS

It's not a bargain if you have to replace it every few years.

### THERE'S NO I-ROD® EQUIVALENT

- I-Rod® has a service life of 15 years or longer
- Imitations can fail immediately
- Contractors are liable if I-Rod® is specified and imitations are installed and fail
- Make sure supplier is selling genuine I-Rod®



Failed I-Rod® imitations.

## MAKE SURE YOUR I-ROD® IS AUTHENTIC

### How to tell if your I-Rod® is genuine:

- All I-Rod® has a brand name and batch number printed as shown
- I-Rod® comes with a certificate of authenticity



# I-ROD® 28 YEAR STUDY

The following images were captured in 2017 during a routine topside inspection of the first offshore structure where I-Rod pipe supports were specified (see the 13-year study for photos of the same support material in 2002). The system was installed

in 1989 for less than \$10,000 USD. These photos show the long-term success of the system at 13 and 28 years when Deepwater Corrosion Services, Inc. visited the structures for inspections in 2002 and 2017.

## 2002: 13 years after installation



### WET CONDITIONS

This fuel gas line is always wet (the green coloration is mold) and the beam paint system has failed, but no corrosion has occurred at the pipe support.

## 2017: 28 years after installation



### FIFTEEN YEARS LATER...

28 years after installation, the fuel gas line shows some paint failure at the support but the I-Rod is still intact.



**LOW BEAM, HIGH-RISK** Another pipe that stays wet, as evidenced by the mold and mildew on its surface. At 13 years after installation, the support was performing well.



### NO CREVICE CORROSION

28 years after installation, the coating is almost completely disintegrated and I-Rod still successfully prevented crevice corrosion.



### EXPOSED TO SPRAY AND SUN

This support remains well-preserved despite being exposed to harsh offshore conditions.



### NEW PAINT, SAME NU-BOLT

The Nu-Bolt has received a few coats of paint over the decades but no new corrosion